

## PRODUCT DETAILS

The DAB JETCOM62M is a composite, self-priming centrifugal pressure pump with excellent suction capacity even when there are air bubbles in the water.

Particularly suited to water supply in domestic installations, small-scale agriculture, gardening and wherever self-priming operation is required.

DAB Jetcom pumps are renowned for their unique self-priming and extraordinary deep suction capability; up to 8 metres at sea level.



## APPLICATIONS

- Household water supply - small dwellings
- Light garden irrigation
- Water transfer
- Washing systems
- Pressure boosting

## FEATURES

- Motor support in cast iron, technopolymer pump body, impeller, diffuser, Venturi tube and sand guard. Stainless steel adjustment rings.
- Carbon/ceramic mechanical seal.
- Asynchronous motor closed and cooled by external ventilation. Max Ambient temp 40 deg C
- Built-in thermal and current overload protection and a capacitor permanently on in the single-phase versions.

## TECHNICAL DATA

<b>OUTPUT POWER (KW)</b>	0.44kW P2
<b>MAX. HEAD [M]</b>	42M
<b>MAX. FLOW L/MIN</b>	45 l/min
<b>MAX PRESSURE</b>	6 bar
<b>LIQUID TEMPERATURE</b>	2 - 35 deg C
<b>MOTOR</b>	Asynchronous TEFC
<b>MOTOR INSULATION</b>	F Class insulation
<b>MOTOR PROTECTION</b>	In-built thermal overload
<b>PROTECTION CLASS</b>	IP44. Terminal board I.P.55

<b>RATED VOLTAGE</b>	220 - 240V 1Ph 50 Hz
<b>RATED CURRENT</b>	3.12A
<b>CAPACITOR</b>	10uF 450V
<b>POWER CABLE</b>	2m long 10 amp rated H05 flex 10 amp 3 pin plug
<b>PUMP BODY</b>	Technopolymer A
<b>INTERNALS</b>	Technopolymer A
<b>MECHANICAL SEAL</b>	Carbon/Ceramic
<b>PACKAGE DIMENSION</b>	L470 x W240 x H240mm
<b>GROSS WEIGHT (KG)</b>	7.5kg

## CURVE

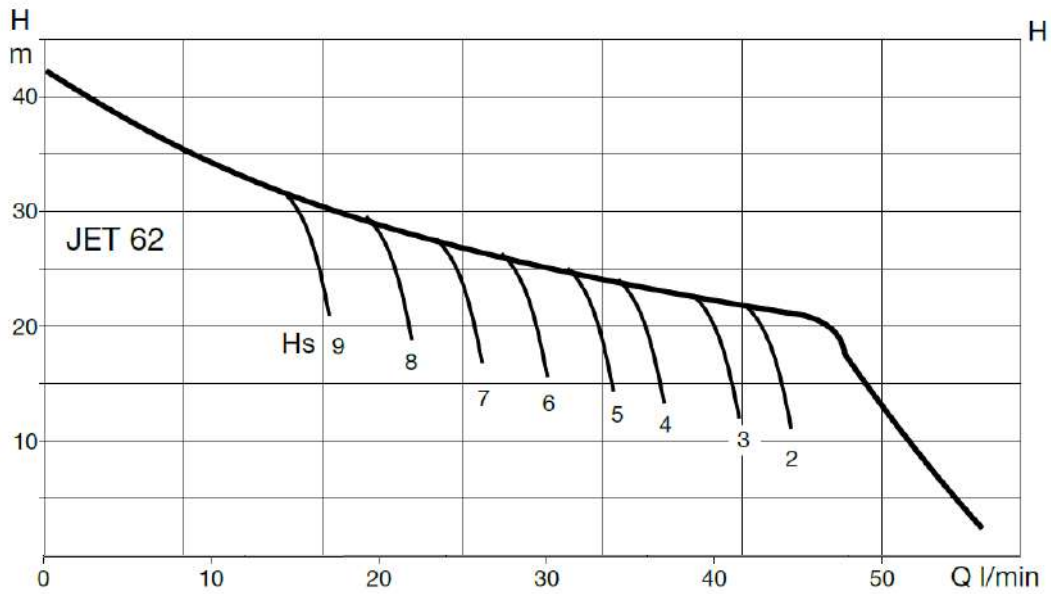

## DIMENSIONS

A	406
B	170
C	122
E	208
F	14
G	111
H	198
H2	144
I	Dia 9
DNA	1" GAS
DNM	1" GAS

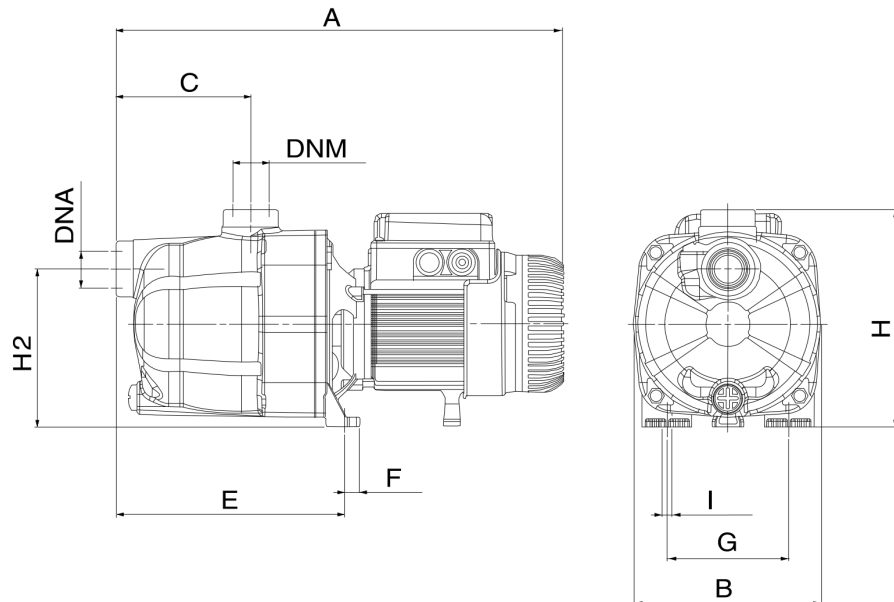

## WARRANTY / CERTIFICATIONS

